



Eurobot 2010
Feed the world



FAQ 1 - 30/09/2009



Feed the world

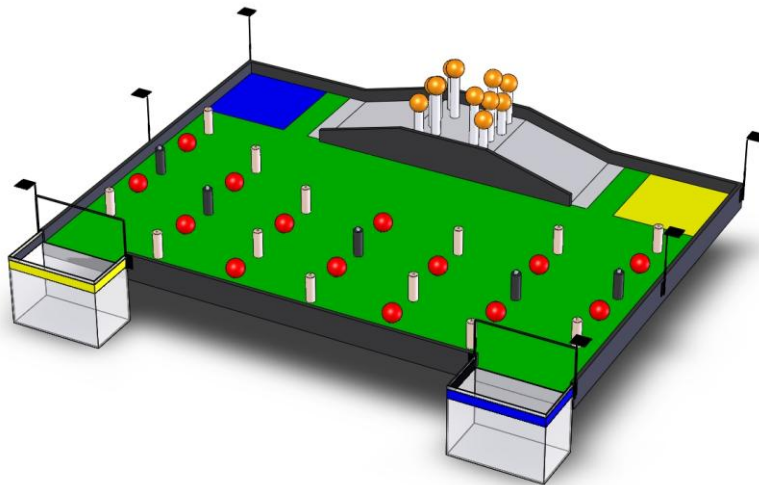



Eurobot 2010

Feed the world



FAQ 1 - 30/09/2009

New:

The emergency Stop Button is allowed beyond 350mm, with a maximum of 370mm.

Question 1:

What's the size of the corn holes?

The holes are 10mm large. The inserts are fixed under the table

Question 2:

What's the trees diameter, there is a missing measure for the trees?

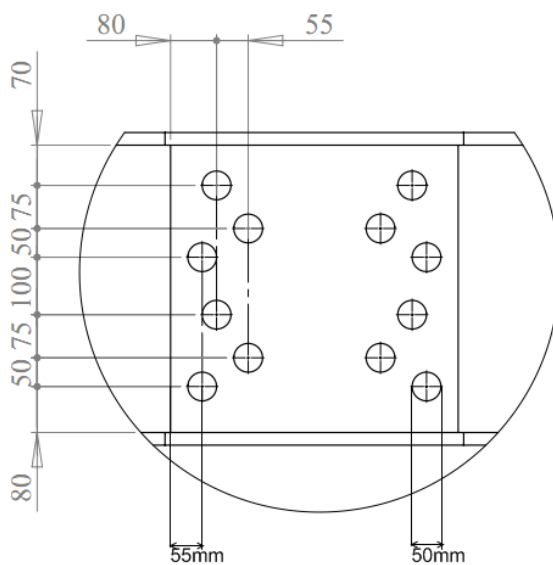

Question 3:

What's the size of the white zone down the slopes?

100mmx5000mm



Eurobot 2010

Feed the world



FAQ 1 - 30/09/2009

Question 4:

There are missing dimensions for the slopes.

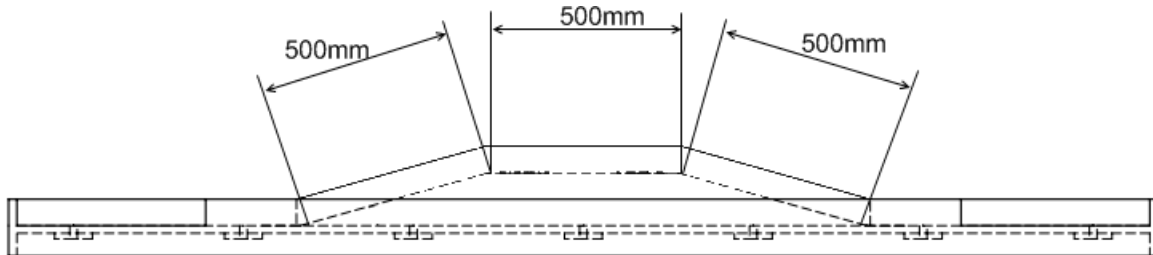

Question 5:

At the beginning of the document (p. 7) ears of corn are Yellow but in plans, they are pearl white, what's the true color?

The true color is pearl white, there is an error on page 7.

Question 6:

On some examples, there are 5 fake ears of corn, is it normal?

There are some errors on pictures, as said in page 9, there are 7 fake elements.

Question 7:

How will be built the pins under ears of corn?

It will be wood plugs.

Question 8:

It's very easy to make corn fall by simply pushing it, is it normal?

No, we are working on it, you'll have the results very quickly.



Eurobot 2010

Feed the world



FAQ 1 - 30/09/2009

Question 9:

Can we have the exact color of cake corn?

RAL9017

Question 10:

Will the constraint of 35cm high for the robot be respected when robots will be on slopes?

We'll take the measure perpendicularly to the ground where the robot is.

Question 11:

Are the robots allowed to make parabolic shots?

No

Question 12:

Is there a limitation for controlled elements?

No

Question 13:

Are trees fixed to the ground?

Yes, trees are part of the table. You can only move playing elements.